

# MEGACOUNT

## 3D STEREO PEOPLE COUNTER TECHNICAL DESCRIPTION

---



## INTRODUCTION

**3D Stereo people counter is made to accurately count the customers of shopping centers and retail stores with dense traffic and in locations with poor lighting.**

The counting is done by detecting the heads of the people walking through, while discounting shadows and specks of light.

The counter is a 138mm x 65mm x 25mm (5.4in x 2.5in x 0.9in) one-unit device with an Ethernet PoE port on its side. There is also a 1/4 inch screw hole on the back cover.

## HOW IT WORKS

Two graphic sensors send the data to the counter's processor that creates a 3D model of the objects' movement, which allows detecting the position and the dimensions of a customer with high accuracy.

Two lenses project the images onto CMOS graphic sensors that digitalize the primary image and send it to the DSP processor. The processor compares both received images and searches for matching parts. Based on the gathered data on the matching parts, it calculates and creates a mathematical 3D model of the location.

Then, using built-in software, the processor detects the heads of the customers who went through the counting point. The processor stores the gathered data in the FLASH memory and later transfers it to the data processing system.

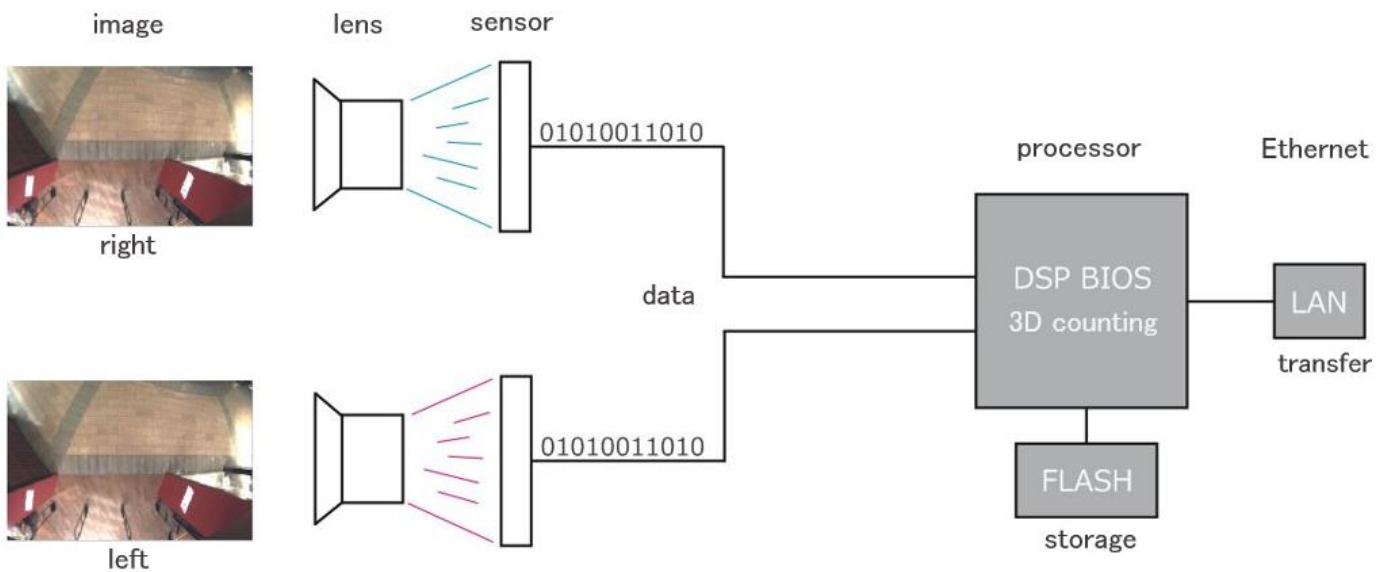

## TECHNICAL CHARACTERISTICS

- Two black-and-white megapixel CMOS sensors
- Accuracy almost 100%
- Installation height 2.5m-6m
- Multisensor: up to 8 counters can be grouped together
- Data recording intervals starting from one minute
- 3D Stereo Vision algorithm for primary data processing
- Built-in DSP processor: all the calculations are done in the counter
- DSP/BIOS real time operating system
- Micro SD FLASH 8Gb
- Automated adjustment to outside lighting (darkness, bright sun, light specks)
- Counting even extra dense traffic
- Height filter
- Discounting children, shadows, strollers, shopping trolleys, bags
- Numerous counting tools: lines, areas, filters, portals
- PoE 48V, power consumption 3W
- Ethernet data transfer interface 10/100 Mbit
- Impact-resistant ABS plastic cover, colour white or black, dimensions 138x65x25mm IP 60
- Automated recovery of the data not completely exported
- (s)FTP, SFTP, DNS, HTTP(s), TFTP protocols
- Export in TXT, CSV, XML, JSON, JPG (tracking maps, heatmaps)
- Automated HTTP, TFTP update
- No license restrictions
- Automatic customer detection and tracking
- Automated floor level positioning
- Fanless cooling
- No additional service needed after the mounting and calibration
- Service life > 20 years
- 1-year warranty
- MegaCount manufacture

## ADVANTAGES OF OPTIC TECHNOLOGIES

- **High resolution:** the counter classifies objects according to their height and therefore discounts shadows and specks of light.
- **Large coverage area:** by using wide-angle lenses, we have significantly improved the counter's coverage. With the installation height of 3m (10ft), the coverage is 4m x 3m (13ft x 10ft), which allows covering all standard entrances with just one sensor.
- **High accuracy:** the accuracy is almost 100% depending on the specifics of the location and traffic.
- **Long service life:** mean time to failure > 20 years; for our counters we use only high-tech sustainable electronic components.
- **Safety:** no laser beaming elements.
- **Fanless passive cooling:** due to a powerful 3D processor, the counter doesn't heat up and doesn't require cooling. The cover is dustproof, IP 60.

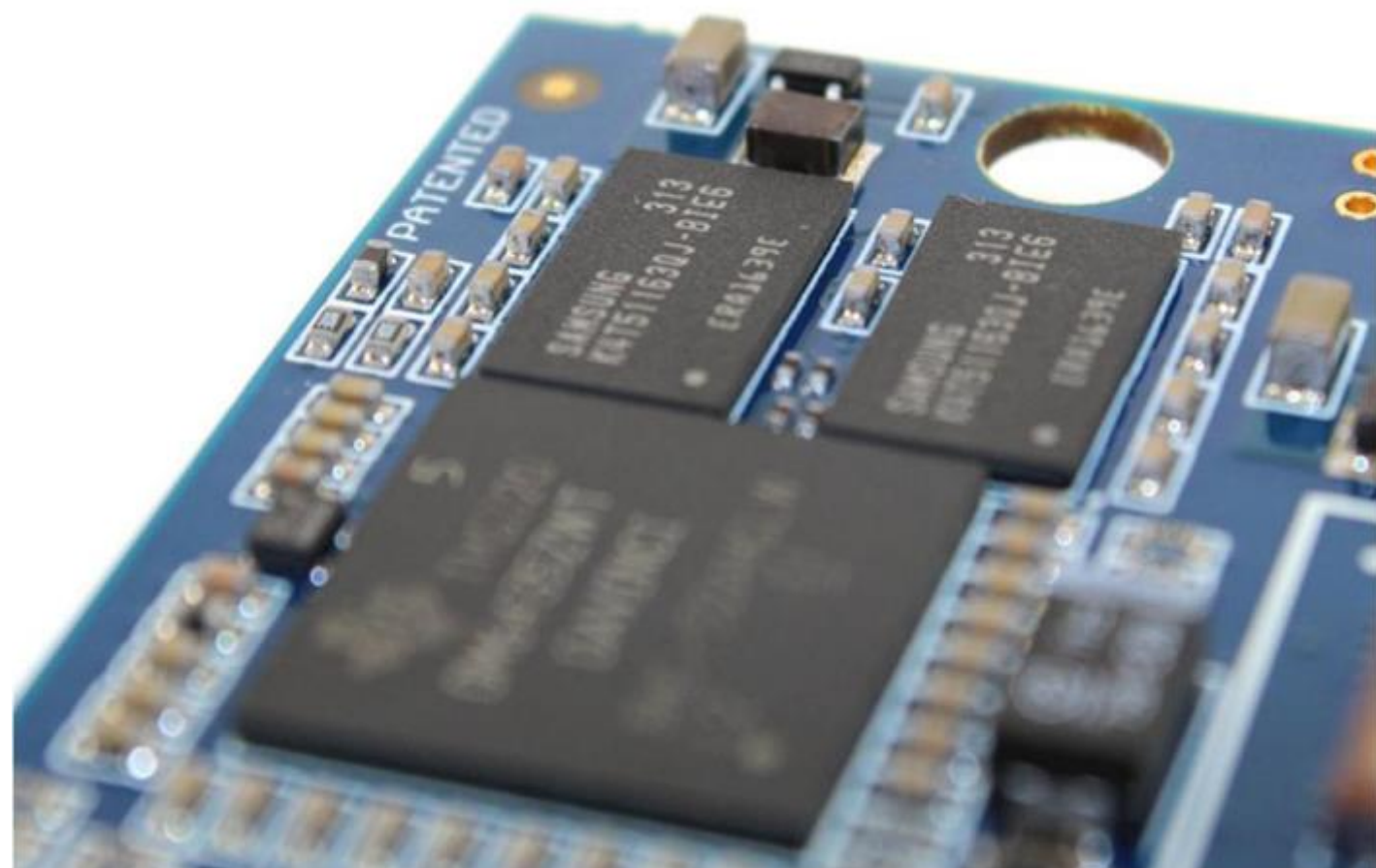

## DATA TRANSFER

**WEB export to the OMEGA system:** the data from each counter is transferred to a processing server by JSON, XML. To collect the processed analytical data, the user connects to the system through the WEB interface in any browser.

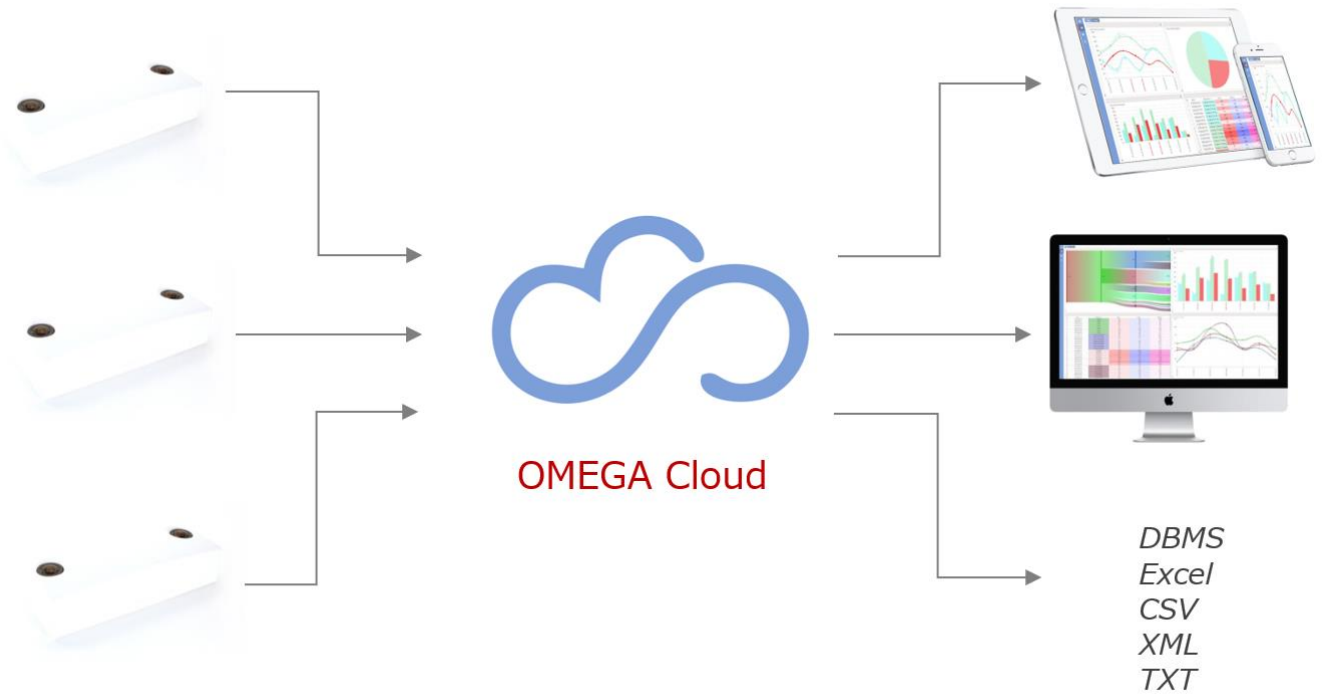

**Flexible export** using HTTP or FTP it can be set up for each counter in any format.

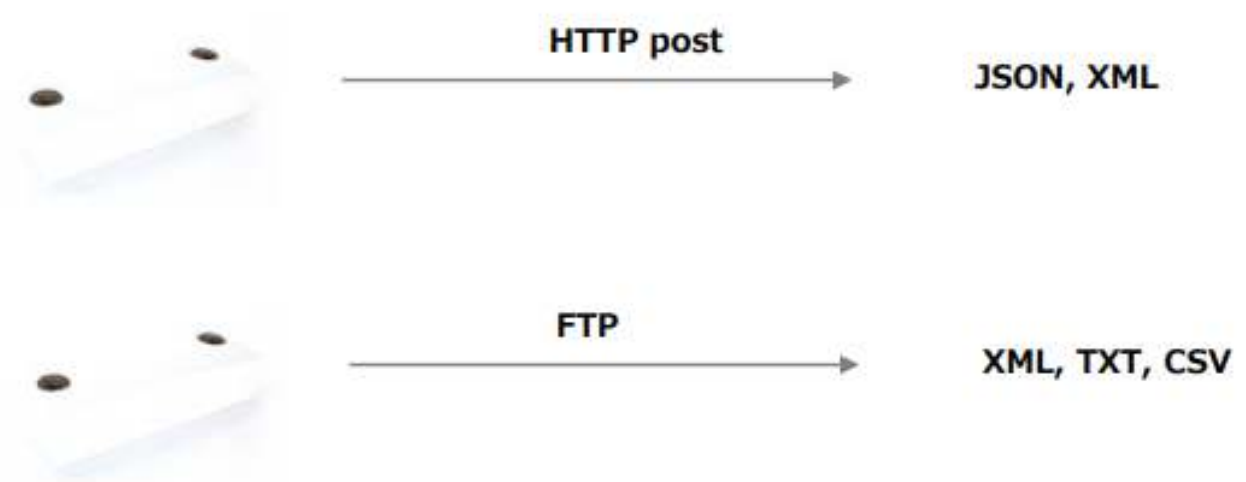

## CONNECTION

Our 3D Stereo counter is connected with a UTP cable by crimping RJ45 plugs or using a patch cord.  
Power supply: PoE injector or network equipment PoE according to the circuit plan below.

### Connection plan for equipment without PoE



### Connection plan for equipment with PoE



MegaCount recommends using 802.3af PoE standard. It's optional to deliver a PoE injector with the counter set.

## MOUNTING RECOMMENDATIONS

Stores and boutiques: mount above the EAS gates. If there is no security gate then mount right above the entrance within the 0.5m (1.6ft) distance from it.

Shopping centers: mount the counter where the customer traffic distribution is at its highest — above elevators, entrances, escalators, travellers, corridors, and pass ways.

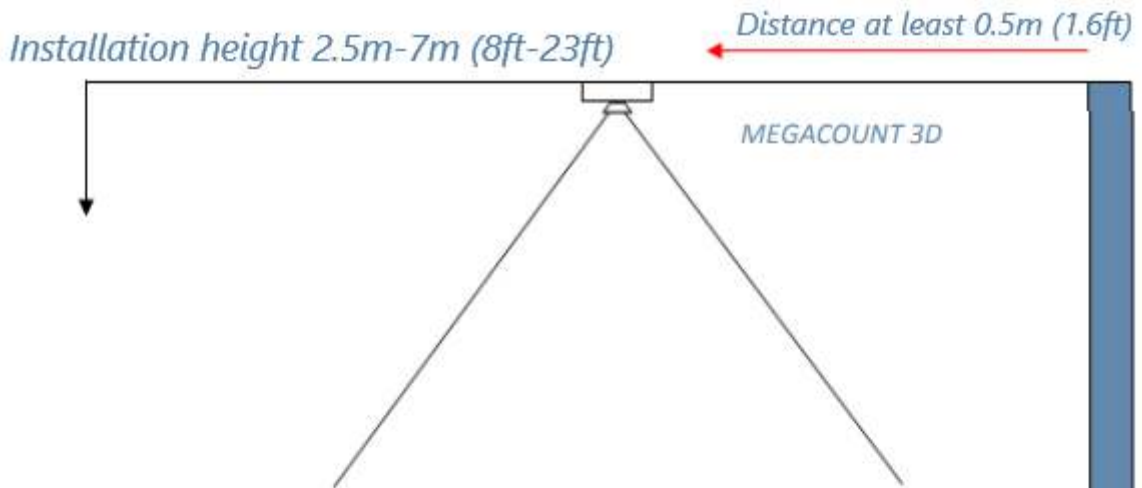

### Calculation of customers' dimensions

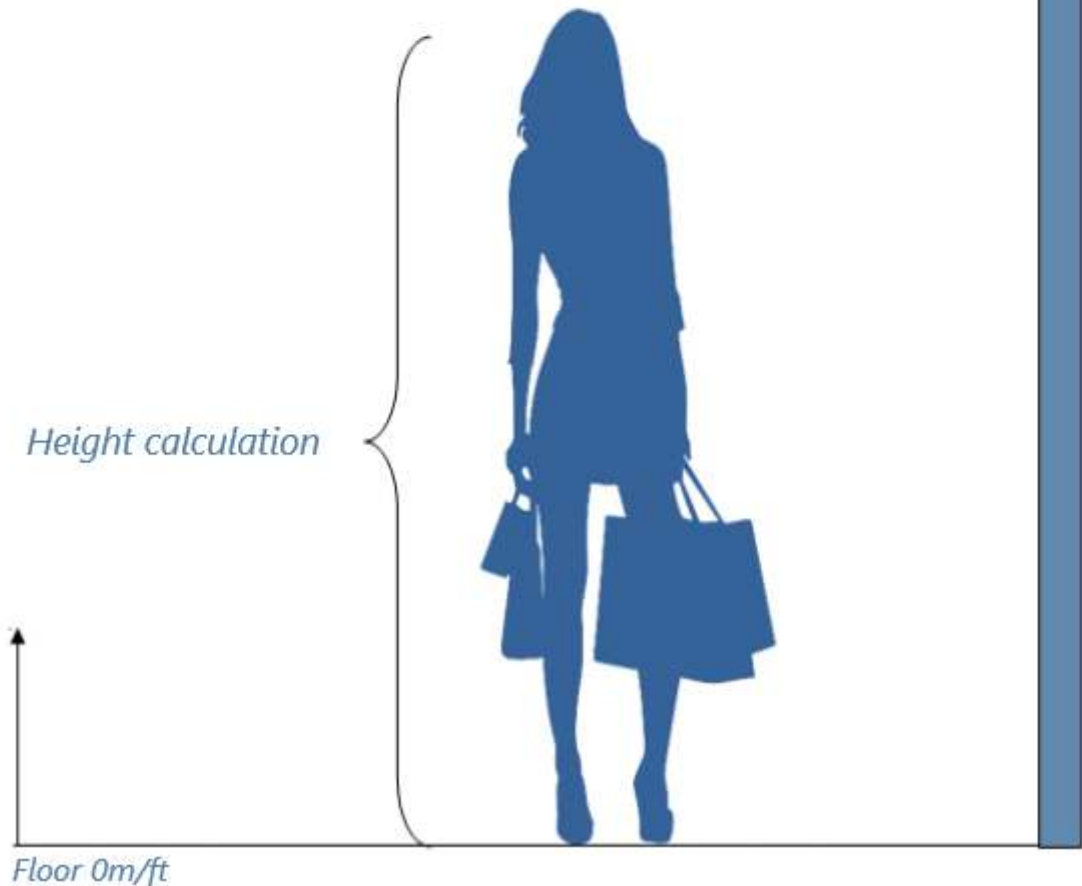

## STYLE

In our design we used modern parts for the base of the counter and have created an elegant device that is small in size. The counter is attached close to the ceiling, and its perfect shape and white-colour cover suit any interior.

A unique method of mounting allows to install the counter on any surface: dropped ceiling, open cell ceiling, drywall, concrete, outboard support.

Suitable for different style shopping centers and retail chains.

**The dimensions are 138mm x 65mm x 25mm (5.4in x 2.5in x 0.9in).**





# COUNTING METHODS

The 3D counter has the unique ability to count customers in ten independent counting zones and you can assign different metrics for each.

Configuring visitors' counting lines				In	Out
+	🗑️	Red	Entrance	0	0
+	🗑️	Blue	Entrance_02	0	0
+	🗑️	Yellow	Entrance_03	0	0
+	🗑️	Green	Entrance_04	0	0
+	🗑️	Purple	Entrance_05	0	0
+	🗑️	Cyan	Entrance_06	0	0
+	🗑️	Light Blue	Entrance_07	0	0
+	🗑️	Light Green	Entrance_08	0	0
+	🗑️	Light Purple	Entrance_09	0	0
+	🗑️	Dark Blue	Entrance_10	0	0

Example: the task is to count people coming in, passing by, going to the right and going to the left. In this case we create four zones and special tools for each of them (lines, portals, exclusion lines).

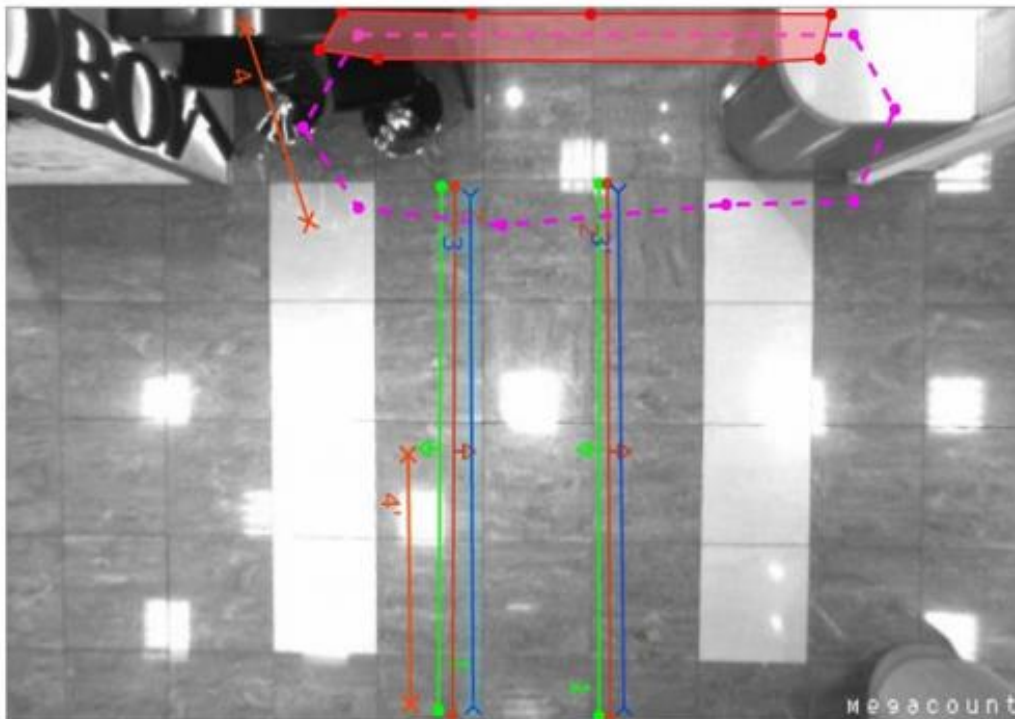

- Pink: In
- Green: To the left
- Red lines: To the right
- Blue: Passers-by

# COUNTING TOOLS

It's possible to employ up to five counting tools and two exclusion filters in different combinations in each of the zones.

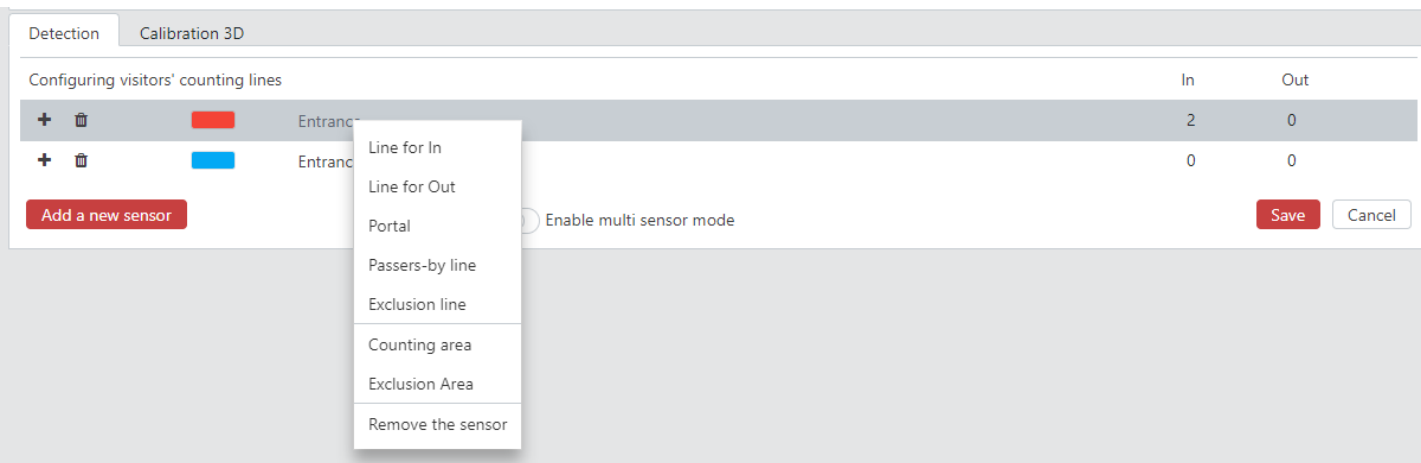

- **Add an in-line:** adds counting lines with the direction indicators to the detection area; a person is counted as coming in when crossing the line in the direction of counting.
- **Add an out-line:** adds counting lines the direction indicators to the detection area; a person is counted as walking out when crossing the line in the direction of counting.
- **Add a crossing line:** adds a line that counts all the people who crossed it without the differentiating between those coming in or out; it's used for counting passers-by.
- **Add an exclusion line:** adds lines by crossing which a person won't be counted by any of the tools; used for discounting the staff.
- **Add a portal:** adds a tool that recognizes people as coming in or out based on their appearance and disappearance in the portal.
- **Add an exclusion area:** adds a filter within which there is NO detection of any kind.
- **Add a counting area:** adds a filter within which the counter detects objects.
- **Delete the sensor:** deletes the selected sensor together with all the counting data from it.

# IN- AND OUT-LINES

In-line: a solid line with the direction indicator.  
Out-line: a dashed line with the direction indicator.

Example with one of each of the lines

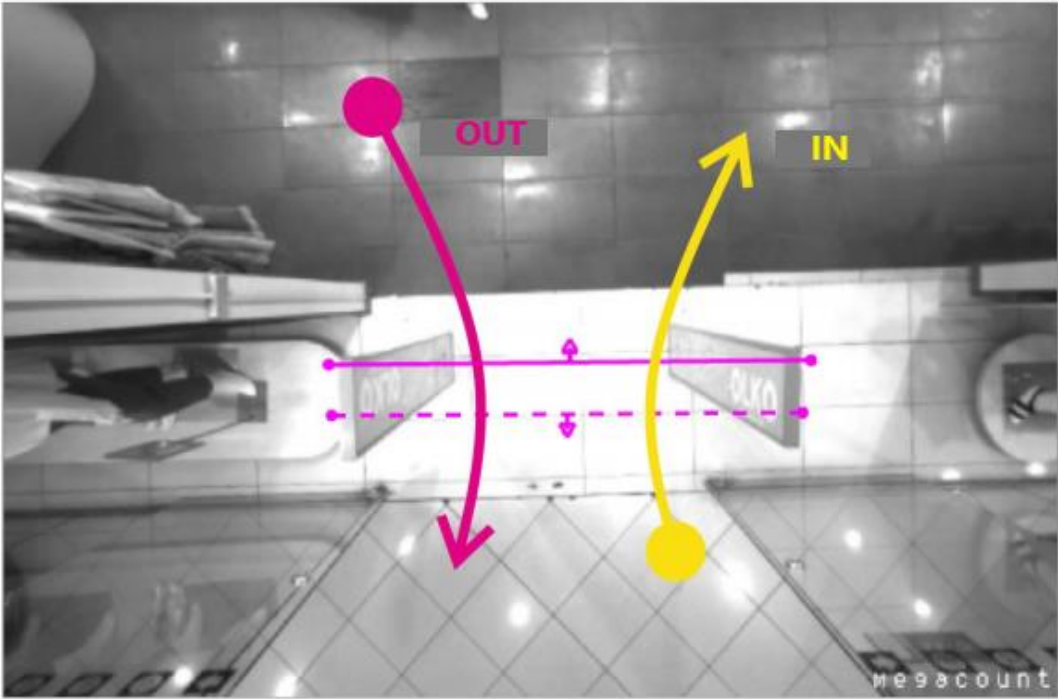

Example with one of each of the lines

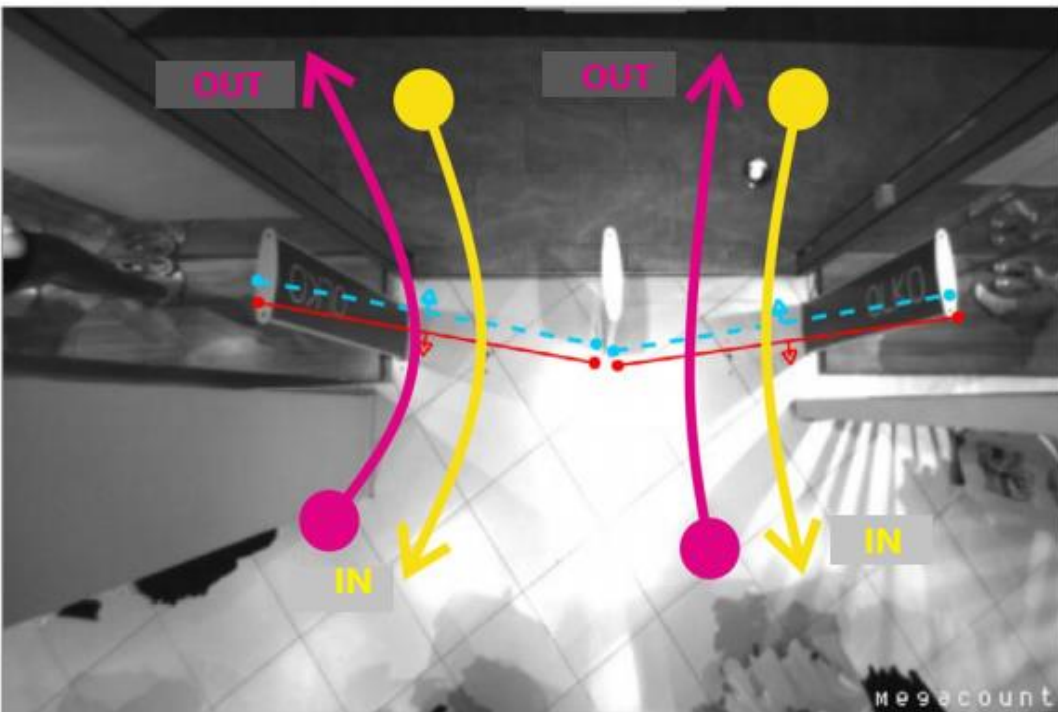

## CROSSING LINES

Crossing lines count general traffic without the differentiation between In and Out, there will be one number for all of those who have crossed it no matter their direction. Can be used for counting passers-by.

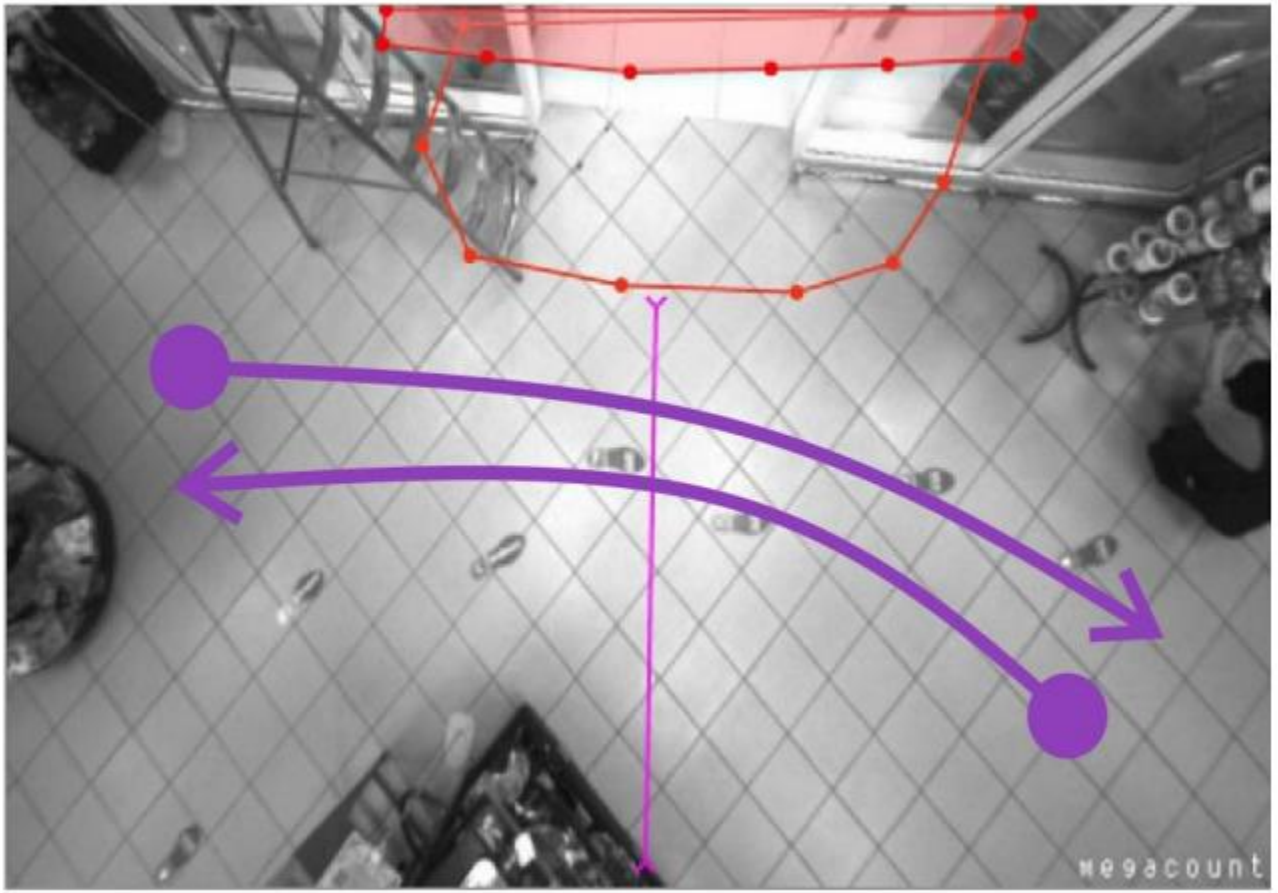

The combination presented above is ideal for mounting the counter outside a venue to count people entering the store and passers-by, which allows calculating the conversion of the passing traffic and customers.

Red: portal, counts In-traffic.

Pink: crossing line, counts passers-by.

Purple: passer-by tracks.

## EXCLUSION LINES

This tool allows discounting the staff. If the object has crossed an exclusion line, it won't be counted whether it crossed that line before or after crossing any of the other counting tools.

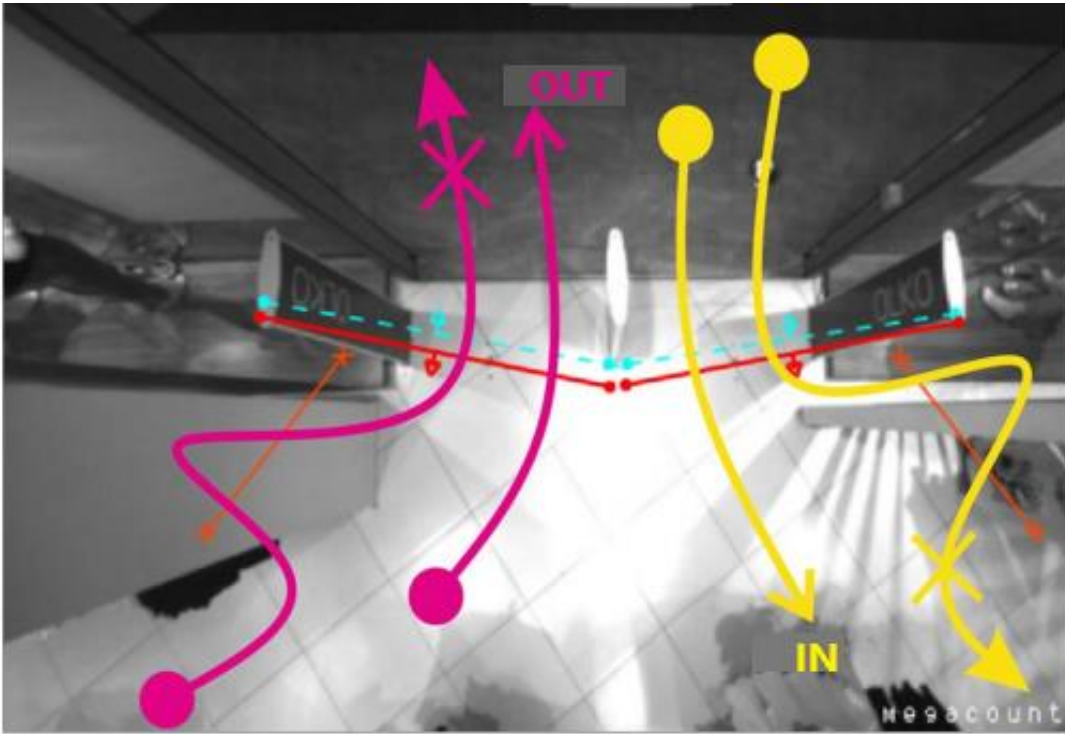

Below is an example of using an exclusion line: it is on the left and the employees are aware of its location. When entering or leaving the store, an employee must cross that line.

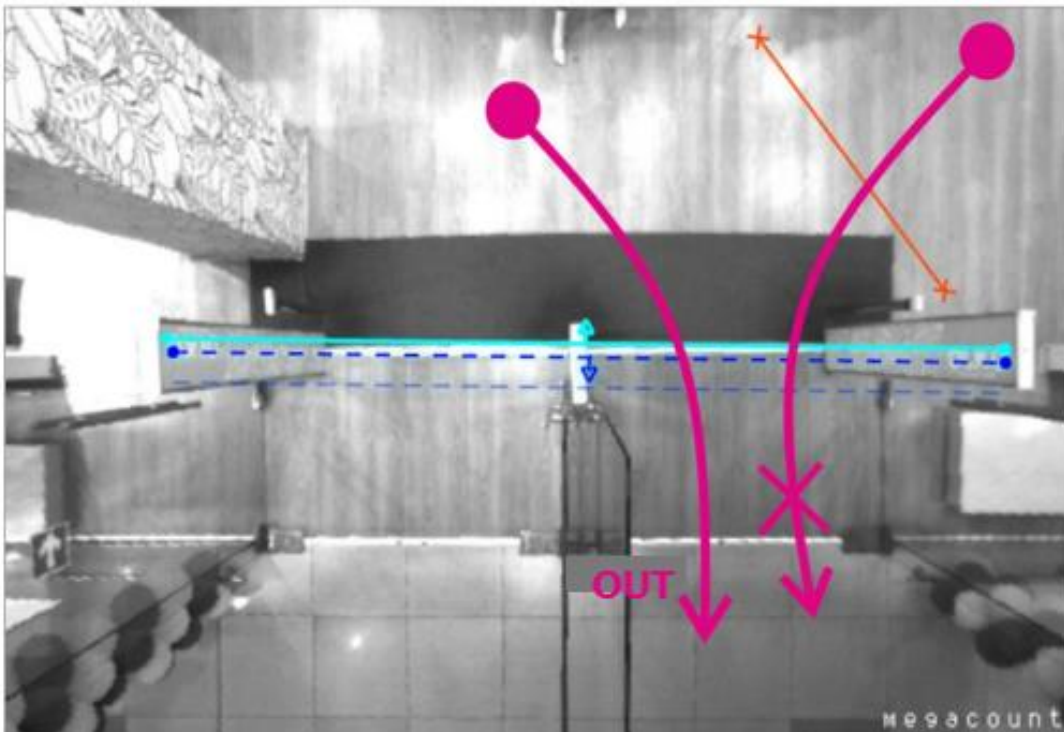



# PORTAL

A tool counts objects based on where they appear.

How it works: if an object appeared within the portal and disappeared outside of it, the object will be counted as coming IN. If an object appeared outside of the portal and disappeared in the portal, it will be counted as coming OUT.

Below is an example of using a portal.

Pink: the portal.

Yellow: the customer will be counted as coming In.

Orange: the customer will be counted as coming Out.

Red: the customer won't be counted (entered the store but didn't go inside and left).

Green: the customer won't be counted (circled around but didn't leave).

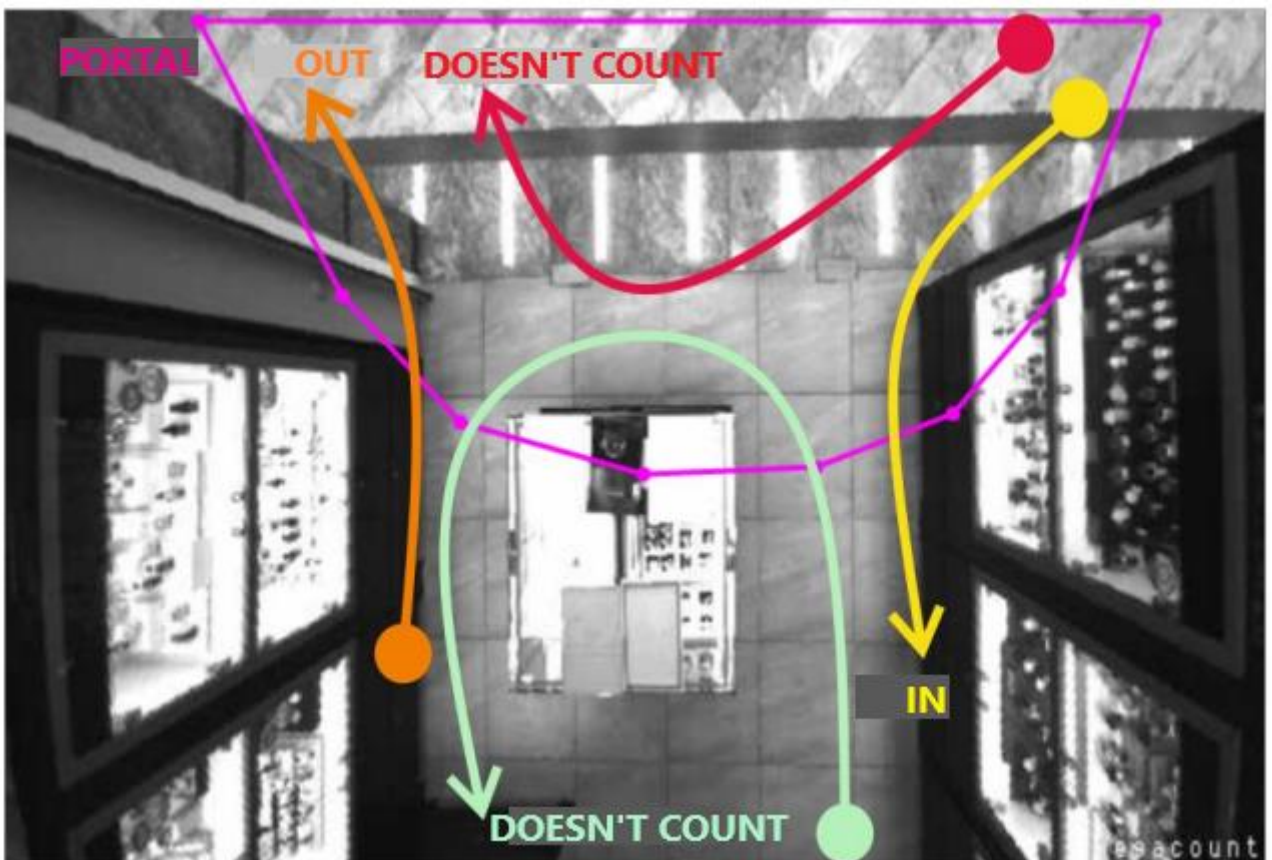

## EXCLUSION FILTERS

The counter detects people only outside the filtrated area. It can be used to filter out the doorway or areas where people shouldn't be counted.

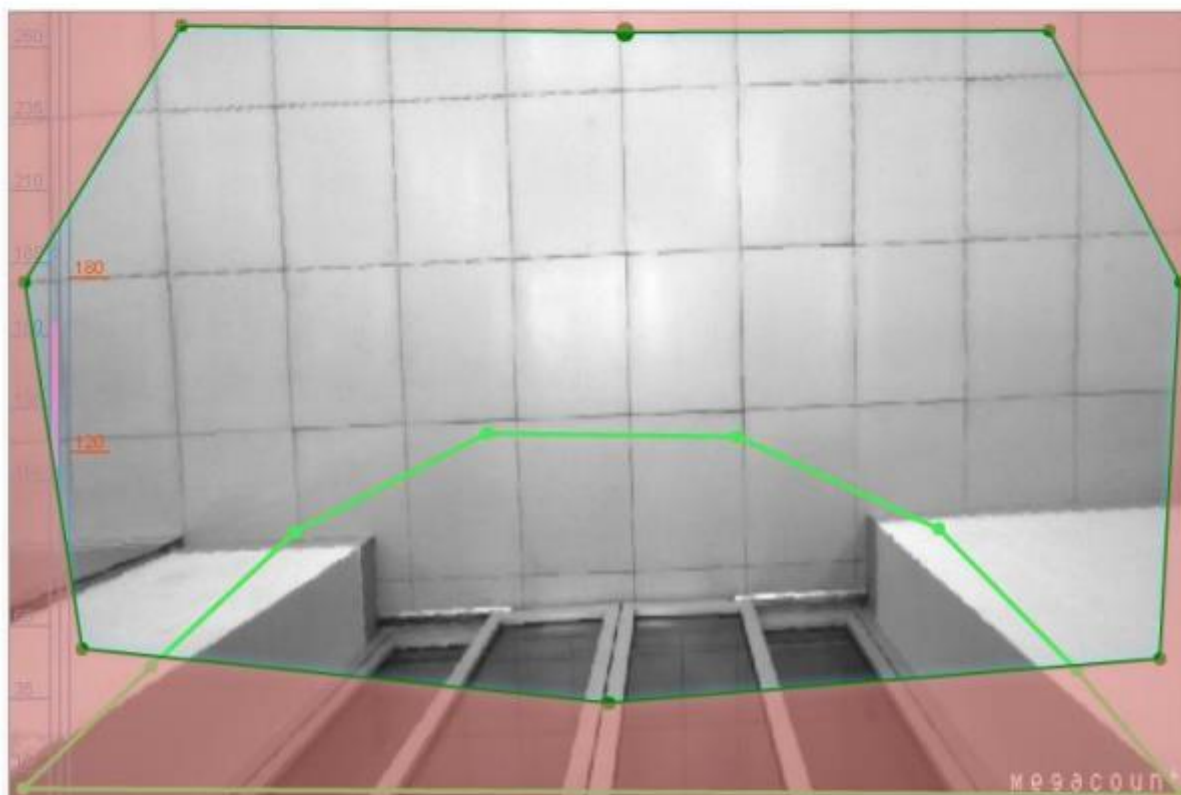
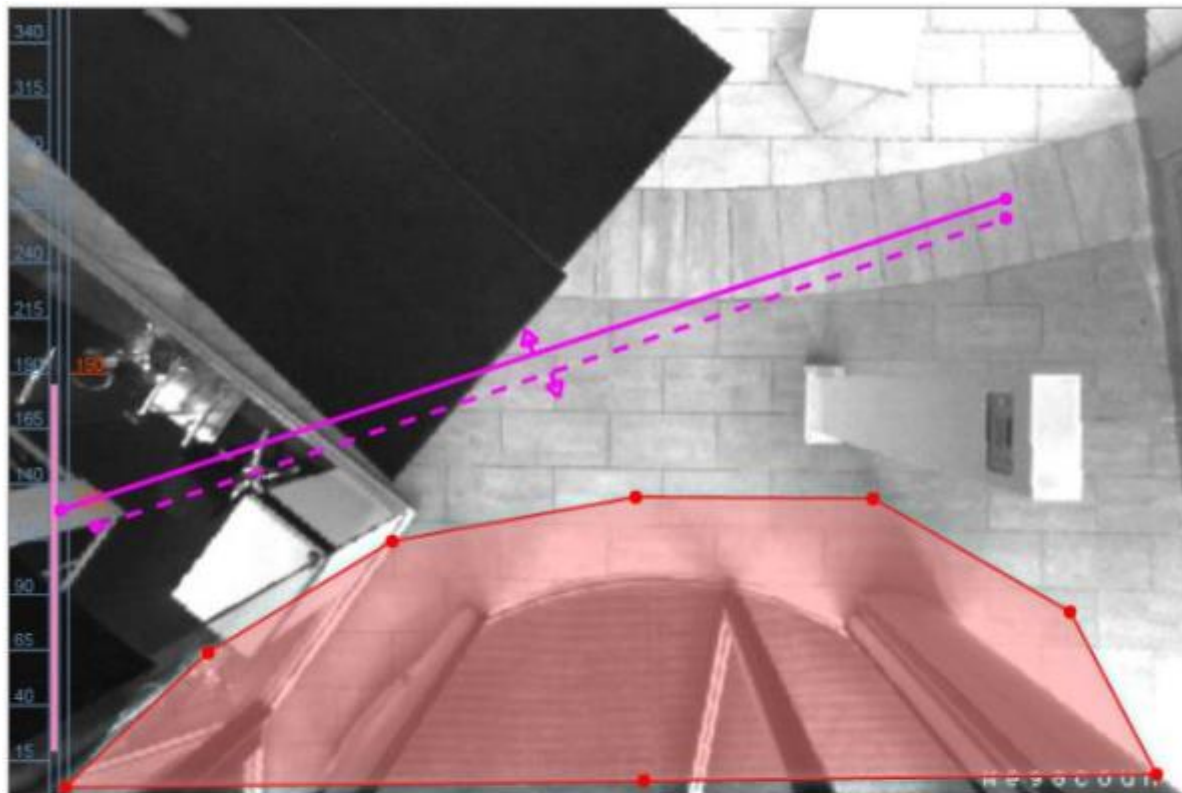

# GRAPHICAL ANALYTICS

## Kinetic tracking maps

Show mean customer movement.

Tracks indicate the direction.

The colour spectrum shows the number of visitors to the area.

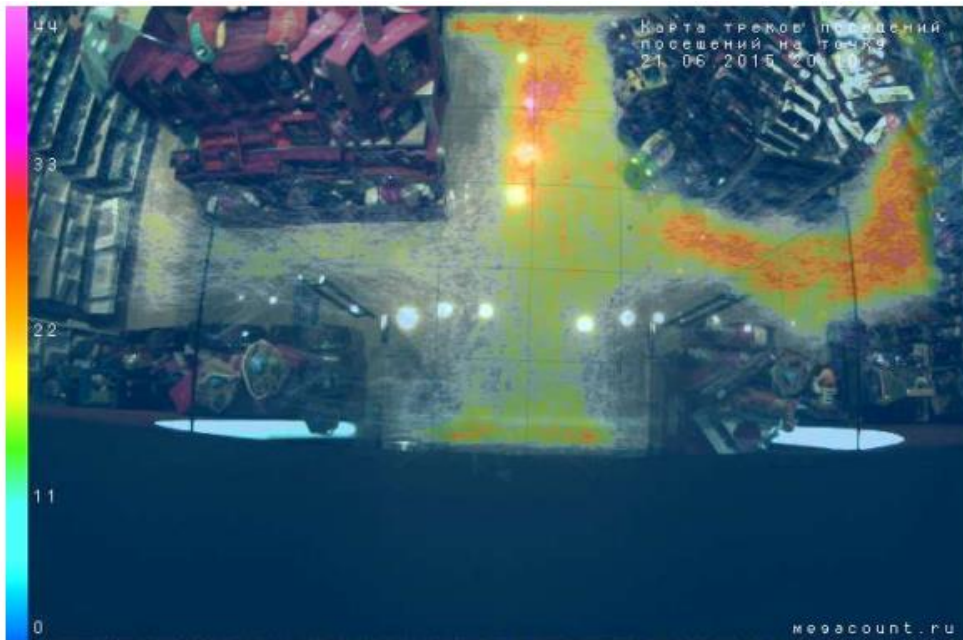

## Heatmaps

Show average duration of dwelling. The colour spectrum indicates the time spent in the area.

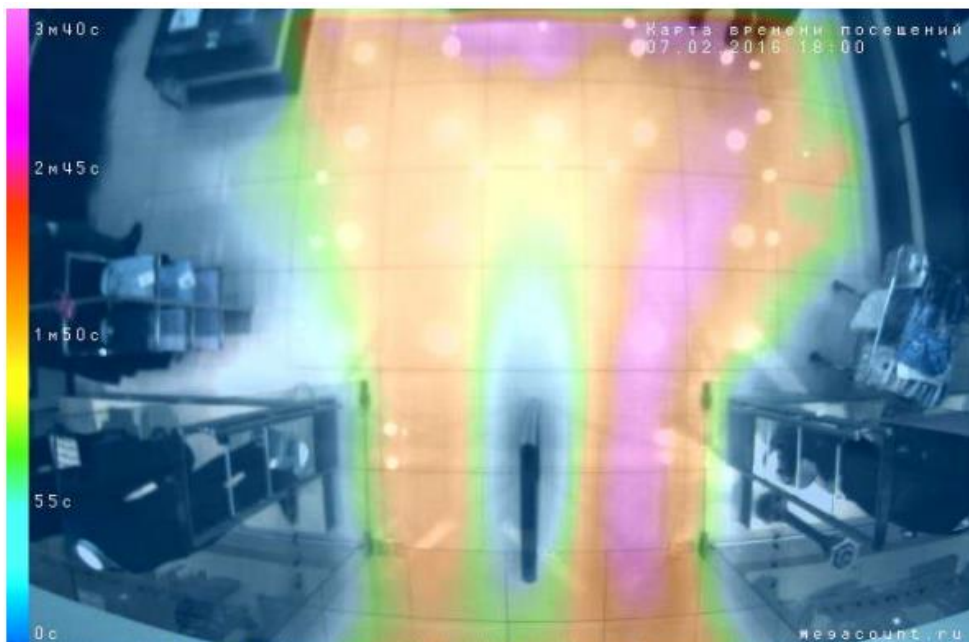



# MEGACOUNT



## DETAILED ANALYTICS AT HAND

Experts in people counting since 2005.  
Manufacturing, mounting, launching plug-and-produce solutions for shopping centers and retail.  
[megacount.io](http://megacount.io)  
[info@megacount.io](mailto:info@megacount.io)